



INSTRUCTIONS BOOKLET
FOR INSTALLATION, USE AND MAINTENANCE

SOLAR PANEL MOUNTING FRAME

SOLAR PANEL MOUNTING FRAME



Dear Customer,

Thank you for choosing a Solar Power Mounting Frame by VERSOL GROUP.
In your interest and to maintain the highest level of performance and duration of your framework, we recommend that you follow the instructions contained in this booklet and have regular maintenance performed by qualified personnel.
We would like to remind you that failure to follow the instructions contained in this booklet may invalidate the guarantee

CE 0085

CONTENTS

INTRODUCTION	PAGE-03
SAFETY DURING INSTALLATION	PAGE-03
DELIVERY AND ASSEMBLY COLLECTOR/	PAGE-06
FRAMEWORK INSTALLATION	PAGE-08
COLLECTOR HYDRAULIC INSTALLATION	PAGE-14
COMMISSIONING AND OPERATION	PAGE-18
MAINTENANCE	PAGE-19

1. Introduction

Lightning protection

If the height where the collectors are to be installed exceeds 20 metres and the building is not equipped with the lightning protection it is necessary to connect all electrically conducting elements with an earth rod (minimal earth rod cross-section – 16mm²) with compensating potential.



If the height at which the collectors are installed is less than 20 metres lightning protection is not required.

If the building is equipped with the lightning protection it is important to check the connection of the solar system to the lightning protection. That task should be performed by an electrician.

Recycling

Used solar collectors can be returned to the manufacturer for recycling.



2. Safety during installation

THINK SAFE when commencing the installation work!!

2.1. Notes included in the instruction.

The installation instructions includes important information concerning safety and proper positioning of the collectors on the roof and the correct execution of the hydraulic connection. Drawings and information included in the instructions apply to a vertical installation of the collectors.

Installation of the collectors can only be performed by professional qualified personnel with water supply and gas systems experience.

Upon completion of works the installer should hand over the installation instructions to the customer and clearly explain the principles of operation and directions essential to proper operation of the solar system.

2.2 Application

These instructions include a description of an assembly set to carry out the installation of solar collectors on a roof or flat surface with the inclination of 45°.

The assembly set to be used to perform the installation of solar collectors - it must not be used to install different devices on the roof. Installation of only solar collectors on the supporting structure guarantees its safe operation.

Collectors mounted on the ground must be secured to the ground by a foundation slab/plinth/metal frame (not included in the standard kit). The minimum distance between the bottom edge of the collector and surface of the ground must be min. 400mm.

3. Before commencing the installation.

WARNING!



As Roofwork can be dangerous it is recommended to hire a roofwork company or receive roofwork training.
DANGER OF GETTING SCALDED or BURNT.



The collectors and assembly materials can be exposed to solar radiation for a long time, there is a risk of getting scalded by hot elements.

In order to avoid the danger of scalding you should:

- use protective clothing,
- cover the collectors and the assembly materials with canvas cover (to reduce radiant heat from the sun).

3.1 Check delivery



Before commencing the installation it is necessary to check that the delivery is complete (see figure below) and the delivered components are not damaged.

- if damaged parts are discovered the defective elements or parts should be replaced immediately.
the replacement elements or parts need to be original spare parts only.

3.1.1. Mounting set for collectors FP2.0CU-AL



1. ECONOMIC TRIANGLE FOR FLAT ROOF

2. MULTISLOT AL PROFILE



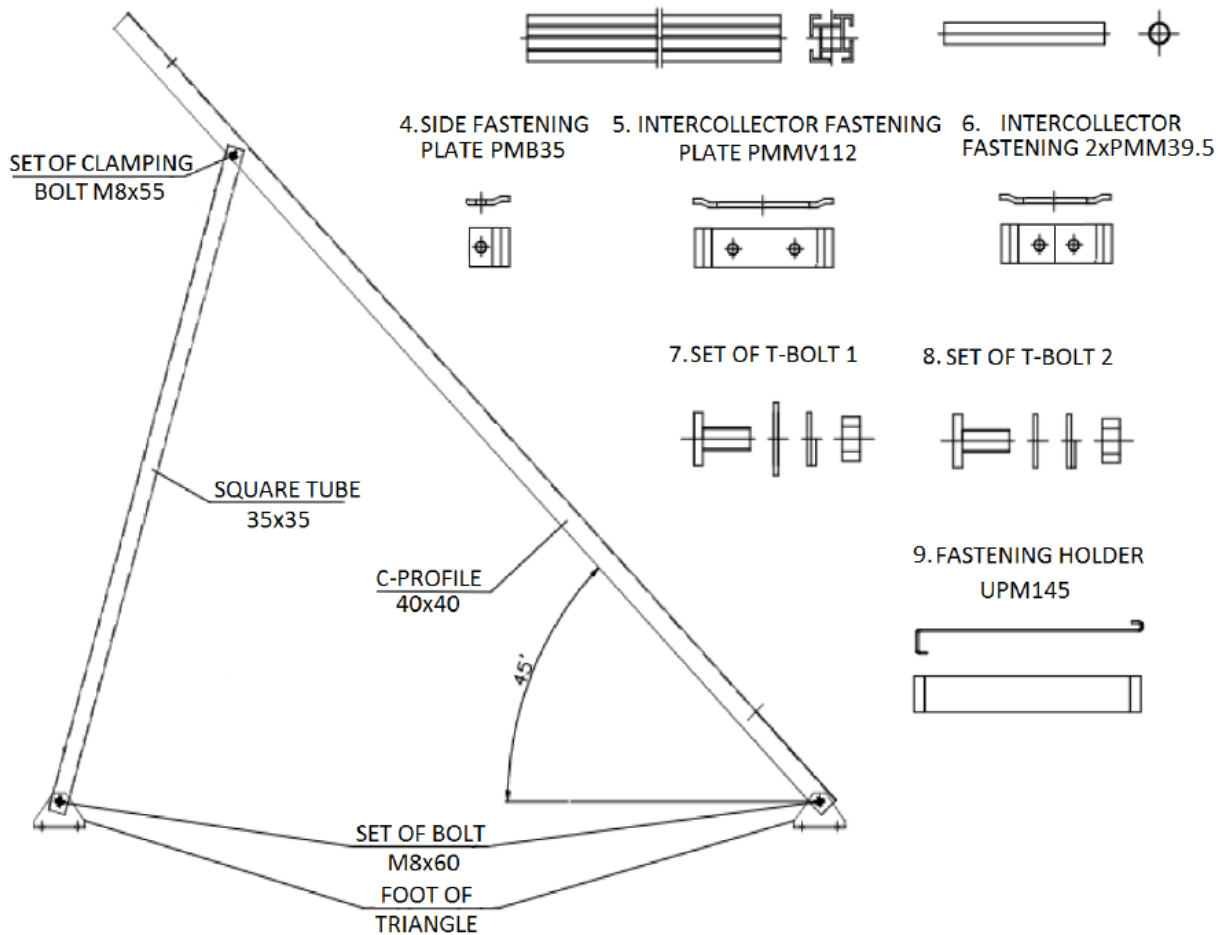

3. CONNECTOR OF THE PROFILE



Delivery Check List – FP 2.0 CU-AL

Position	Name	Unit	1x FP2.0 CU-AL.	2x FP2.0 CU-AL.	3x FP2.0 CU-AL.	4x FP2.0 CU-AL.	5xFP2.0 CU-AL.
1.	Economic triangle (light triangle)	pcs.	2	3	4	5	6
2.	Multi-slot AL Profile	M	2 x 1,2	2 x 2,4	2 x 1,2 +2 x 2,4	4 x 2,4	4 x 2,4 +2 x 1,2
3.	Connector of the AL profile	pcs.	0	0	2	2	4
4.	Side fastening plate PMB35	pcs.	4	4	4	4	4
5.	Inter collector fastening plate PMM112	pcs.	0	0	0	2	2
6.	Intercollector fastening plate 2xPMM39.5	pcs.	0	2	4	4	6
7.	Set of bolt 1	Set	4	8	12	16	20
	T-head bolt inox M8x20						
	Washer M8						
	Spring washer inox M8						
	Nut inox M8						
8.	Set of bolt 2	Set	4	6	8	10	12
	T-bolt inox M8x20						
	Washer inox M8						
	Spring washer inox M8						
	Nut inox M8						
9.	Fastening holder UM145	pcs.	2	4	6	8	10

3.1.2 Delivery Check List – connecting system

ELBOW FI22 x 3/4"M	COMPENSATOR FI 22 x 22	CROSS-FITTING FI22x3/4"M	CLAMPING UNION PIPE
			

CONNECTING SYSTEM FOR COLLECTOR FP2.0 CU-AL			NUMBER OF ITEMS				
Lp.	DESCRIPTION	Unit	1	2	3	4	5
1.	CROSS-FITTING FI22x3/4"M	pcs.	1	1	1	1	1
2.	CLAMPING ELBOW FI22 x 3/4"M	pcs.	1	1	1	1	1
3.	COMPENSATOR FI22xFI22	pcs.	0	0	0	1	1
4.	CLAMPING UNION PIPE FI22	pcs.	0	1	2	2	3

3.2 Transport and storage.

- during transport the collector connectors are protected by rubber
- caps,
 - collectors should be stored in a dry place. If the collectors are stored outside they should be protected against weather conditions.

3.3 Technical Documentation

A circular icon containing a lowercase letter 'i', representing information or a note.

Solar installation set consists of different components. Before installing any of the components you should become familiar with the instructions. Separate installation instructions are attached to each device or item of equipment.

- solar collectors installation instructions pump set
- installation instructions
- solar controller installation instructions hot water
- calorifier installation instructions
-

3.4 Additional tools and equipment

- harness/rope, scaffolding, roof ladder or crane (for high level work).

3.5 Location of a collector

The Mounting Frame construction allows you to mount the solar panels at an angle of 45° only. The distance between the Mounting Frame feet are as the dimensions shown on drawing p.4.7 (Installation of Mounting Frame)

Permissible snow and wind load amounts to max. 2,0 kN/m².

Collectors array should be located in such a way that the absorber will not be shadowed by the adjacent buildings, trees, etc. In case of a larger number of collector arrays it is important that the front row of the collectors does not shadow the collectors behind.

3.6 Technical data for the flat collector: FP2.0 CU-AL

FP 2.0 CU-AL	Symbol	Value	Unit
Width	A	1006	mm
Height	B	1988	mm
Depth	C	85	mm
Collector weight	M	40	kg
Area	S	2	m ²
Connectors: Cu pipe	Φ	22	mm
Fluid volume	V	1,8	dm ³
Max working pressure	p _{max}	6.0	bar
Optimum flow min. -	m	60-90	dm ³ /h
max.		50-220	

4.6 The number and spacing of triangles support

For the first collector need two support triangles. For each of the next collector you must use one more support triangles. Spacing of the support triangles depends on the number of mounted collectors as follows

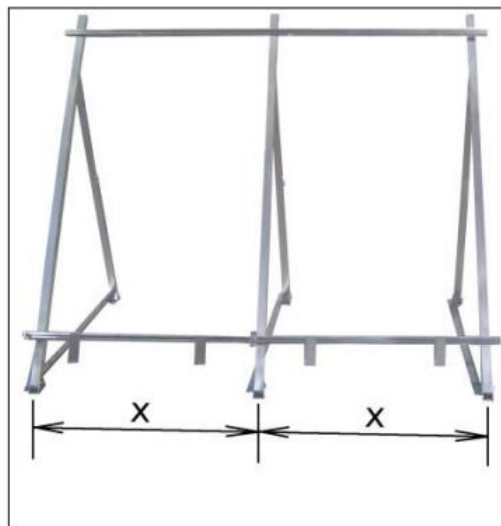

Number of collectors	Number of triangles	Distance between the triangles [mm]
1	2	0,805
2	3	0,955
3	4	1,005
4	5	1,030
5	6	1,045

4.7 Installation of supporting triangles

Base of mounting set are the supporting triangles. All triangles adjust in the same way

Before assembly the supporting triangles you have to set all the elements as shown in the following figure.

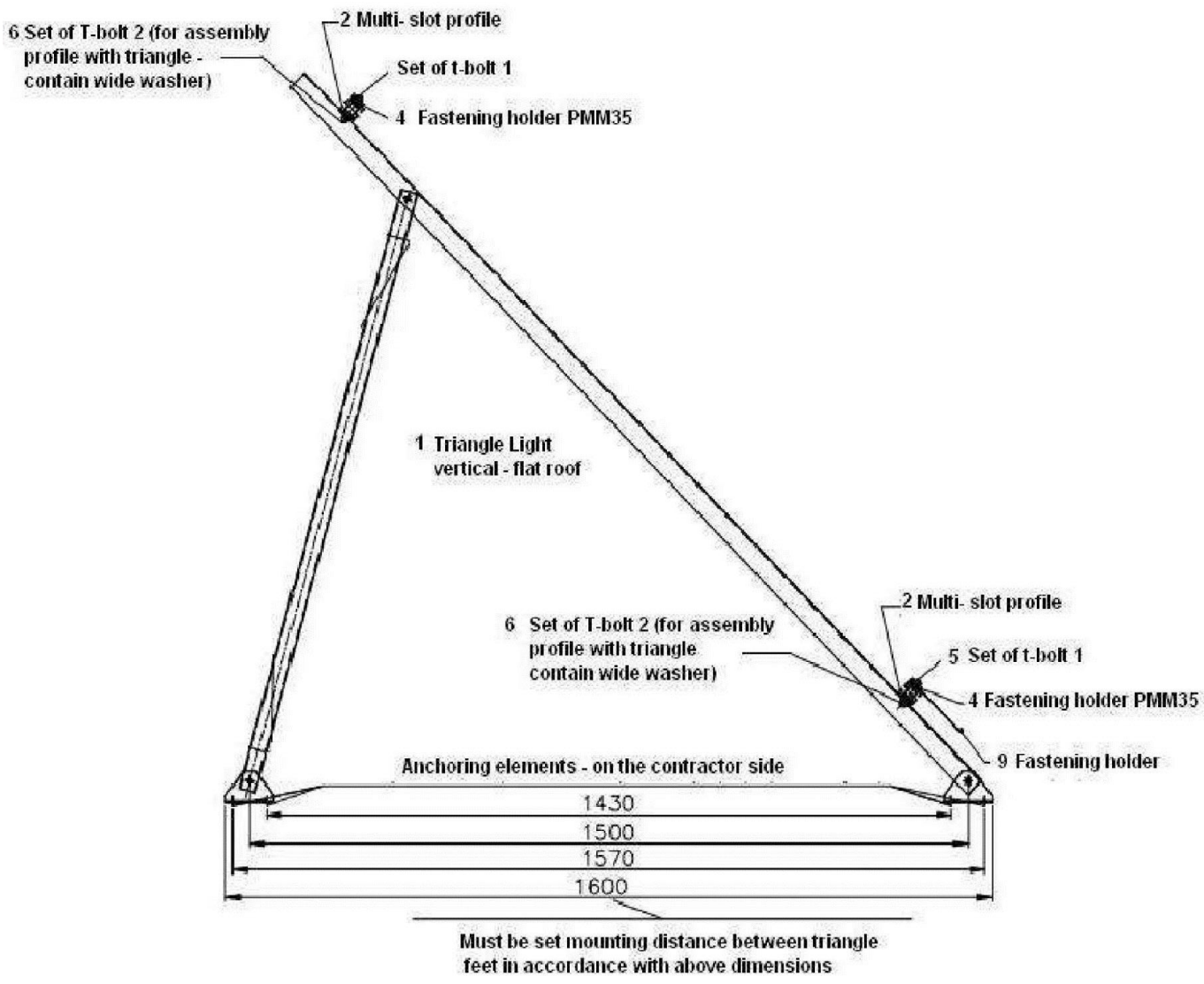

4.8 Number and spacing of multi-slot sections

The assembly set includes an adequate number of multi-slot sections depending on the number of collectors.



Assembly triangles are provided with holes for installing the profile rails.

Tab. Joint length of sections for a given quantity of collectors. The table provides a joint number of sections and connectors for the upper and bottom set of sections.

No of collectors	FP2.0 CU-AL.	
	Profile 1120 mm	Profile 2240 mm
1.	2 pcs.	-
2.	-	2 pcs.
3.	2 pcs.	2 pcs.
4.	-	4 pcs.
5.	2 pcs.	4 pcs.

4.9 Connecting the multi-slot sections

Multi-slot sections should be connected with each other in accordance with the table of configurations, see the figure below.

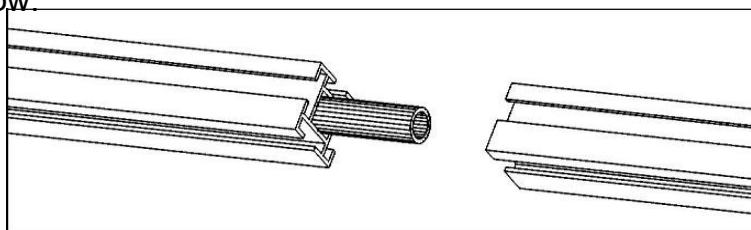

Directions!



In order to avoid an uncontrollable displacement of a connector, screws can be used as distance elements (screws are not delivered with the set). The connector itself is not assembled.

- screws need to be screwed in the sections at the distance of $x = 105$ mm from the edge,
- using a delivered connecting component you should join the sections with each other.

4.10 Connecting multi-slot sections with supporting triangle

Bolts, which were delivered with the set, should be placed in the multi-slot sections in such quantity as the number of supporting triangles, see the figure below.

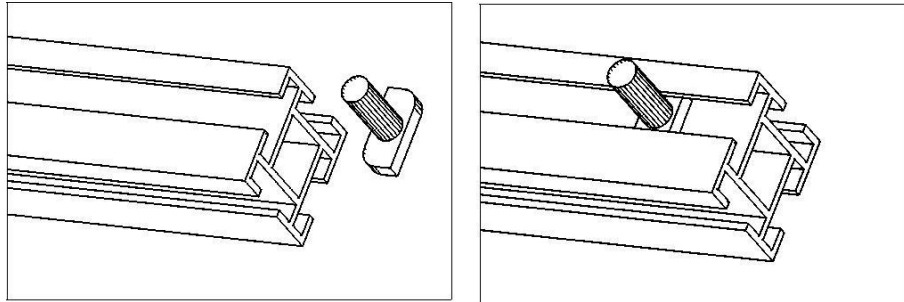

Taking into account spacing of the supporting triangles and multi-slot sections, the profile rails must be bolted with the supporting triangles, as in the figure below.



4.11 Mounting a collector on a multi-slot section.

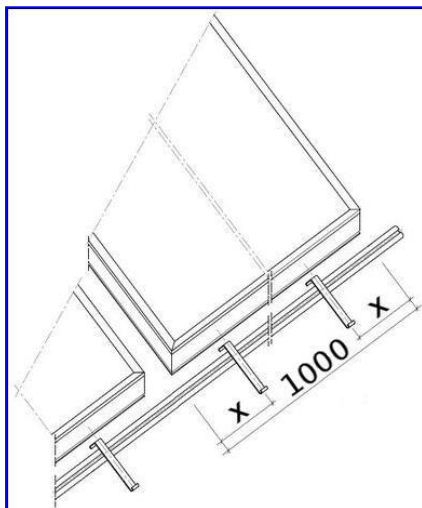

Each collector should rest on two fastening holders which protect it against sliding down.

Fastening holders should be located at the distance of $x = 200 - 250$ mm from the collector's edge.

4.11 Assembly of the fastening holders.

Collector's fastening holders must be fixed in the upper gap of the bottom multi-slot section, as shown below.

Attach the fastening holder on the wider edge of the multi-slot section

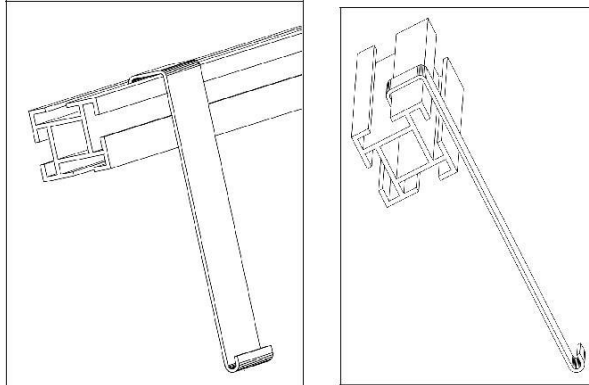

4.12 Fastening the structure to the surface

After assembly the supporting structure needs to be located at its place of destination. The supporting structure must then be fixed to the surface with anchor bolts to protect it against being torn out of the surface.



Mark out the places of fixing the structure to the ground through the holes in the foot of the supporting frame.



After marking out the holes you should then:

- unbolt the foot of the supporting frame (put gently the structure away to be able to work freely),
- make the anchor holes,
- fix the base to the surface,
- bolt the foot of the supporting frame.

5. Installation of the collectors

5.1 Installation of the collectors on the supporting structure.

During the installation of the collectors all safety rules must be obeyed.

Hazard



- when the work on the roof is carried out it is necessary to obey safety rules in order to avoid accidents,
- during the work on the roof the installers should be protected against falling by wearing safety harness fastened to secure fixing,
- installation should be carried out by at least two persons,
- protective clothing needs to be worn at work,
- upon completing the installation it must be checked if the assembly set and the collectors have been installed in a stable way.



Directions!

During transport and installation the collectors need to be protected against falling down.

There are four fasteners for each collector, two on each profile.

- place the bolts in the multi-slot sections, two for each collector,
- locate the collector on the multi-slot sections in such a way that it is supported by the bottom fastening holders,
- collectors should be hydraulically connected by means of a compensator (see 6.3.1),
- mount the fastening plates at the bottom gap of the collector's frame, screw the nut with the bolt located in the section, as shown below.

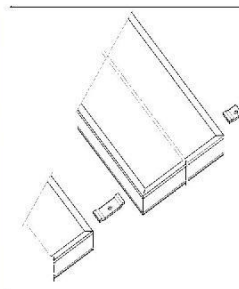

6.0 Hydraulic connection of the collector

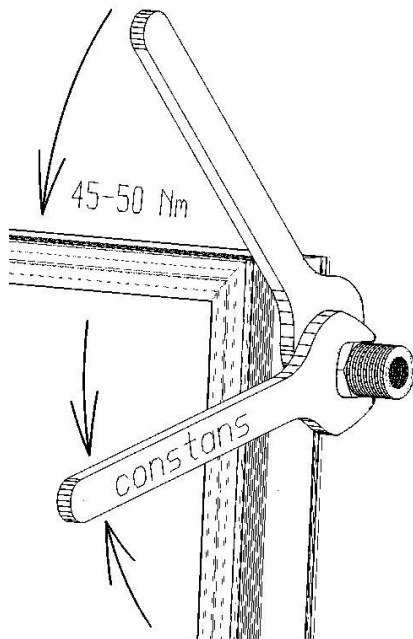

ATTENTION!

**ALL CLAMPING CONNECTIONS
SCREW WITH STRENGTH 45 -50
Nm COUNTER DURING SCREWING**

**Counter wrench with the connector
can not change the position during the
screwing**

**In case of leakage, tighten the clamping
connections with a force of max 80 Nm**

**In case of further leaks, use sealant Loxeal 8672 according
to instructions on the package sealer.**

6.1 Hydraulic connection of the collectors FP2.0 CU-AL



Directions!

Hydraulic conduits and fixtures can be connected at the left or right side of the collector battery. The instruction presents the connection at the right side, as an example.

One-sided connection of maximum 5 collectors.

When forming a battery you can connect maximum 5 collectors.

6.1.1 Connecting the collectors with a clamping pipe union.

Collectors FP2.0 CU-AL – connecting upper connectors pipe

- 1 – connector pipe of the collector
- 2 – strengthening sleeve
- 3 – pipe union nut
- 4 – clamping ring
- 5 – compensator



Mount the compensator on the first collector, then move the second collector closer and fasten the pipe union on both collectors.

- place the strengthening sleeve (2) in the connector pipe of the collector (1),
- pipe union nut (3) should be put on the connector pipe of the collector (1), - clamping ring (4) should be placed on the connector pipe of the collector, - screw the nut (3) onto the pipe union body,
- place the strengthening sleeve in the connector pipe of the second collector,
- put the nut on the connector pipe of the second collector,
- place the clamping ring on the connector pipe of the second collector,
- move the second collector closer to the compensator,
- screw the nut onto the compensator.



Directions

The nut should be tightened up so as to secure the leak-tightness of the connection, however, not too strong in order to avoid damage to the connector pipe of the collector.

6.3.2 Connection of the collectors power supply *1

- 1 – connector pipe of the collector
- 2 – strengthening sleeve
- 3 – nut
- 4 – clamping ring
- 5 – elbow body
- 6 – gasket
- 7 – insulated flexible hose



- strengthening sleeve (2) in the connector pipe of the collector (1), elbow nut (3) should be put on the connector pipe of the collector (1), - clamping ring (4) should be placed on the connector pipe of the collector (1), - screw the nut (3) onto the elbow (5),
- flexible hose (6) needs to be screwed on the elbow (5),
 - connect the flexible hose to the solar system.

*1 power supply = inlet of cold fluid

*2 return = Outlet of warmed fluid

6.3.3 Connection of the collector return *2

- 1 – connector pipe of the collector,
- 2 – strengthening sleeve,
- 3 – clamp nut,
- 4 – clamping ring,
- 5 – complete cross fitting with a manual vent and immersion sleeve,
- 6 – insulated flexible hose



- place the strengthening sleeve (2) in the connector pipe of the collector (1),
- put the clamp nut (3) on the connector pipe of the collector (1),
- place the clamping ring (4) on the connector pipe of the collector (1),
- immersion sleeve with the complete cross fitting (5) needs to be placed in the connector pipe of the collector (1),
- screw the clamp nut (3) onto the cross fitting (5) at the left side,
- screw the insulated flexible hose (6) at the bottom of the pipe-cross (5),
- connect the flexible conduit to the solar system.

6.3.4 - Option for mounting an automatic air escape.

If there is not any space for an automatic air escape a manual air escape should be installed.

- 7 – adapter 1/2 x 3/8 "
- 8 – ball valve 3/8 "
- 9 – automatic air escape 3/8 "



- unscrew the manual air escape from the top of the pipe-cross (5),
- successively screw the adapter (7), valve (8) and automatic air escape (9) at the top of the pipe-cross.



Directions!

Due to high temperatures in the solar systems it is necessary to use air escapes made completely of metal.

*1 power supply = inlet of cold fluid

*2 return = Outlet of warmed fluid

6.4 Connection of the temperature sensor Damage to the system



In case of wrong installation of a temperature sensor or damage to the signal cable there is a risk of damage to the system.

- signal cable must be protected against damage (e.g. damage caused by birds, rodents) using a protective coat.

Temperature sensor should be installed in an immersion sleeve.

- insert the temperature sensor into the immersion sleeve,
- protect with a clamping spring against moving out.



6.5 Connection of collecting conduits

Hydraulic connection with collecting pipes should be executed by means of an insulated flexible conduit. **It is not allowed to connect stiff collective pipes directly to the collector.**

The connection of flexible conduits with the system must be done below the level of the air escape.



Directions!

Universal roof ventilators and antenna penetration should be used to execute the passage of conduits across the roof.



Directions!

A cable for the temperature sensor should be laid together with the flexible return conduit.

7. Finishing work

7.1 Inspection of the installation

Upon completion of the installation work it is necessary to:

- inspect the installation correctness of all elements of the system,
- check the system by means of a pressure test,
- flush the system with water,
- fill in the system with the solar agent.

After the pressure test and water flushing of the system it must be immediately filled up with the solar agent. Otherwise, the tightness test and flushing need to be carried out directly before filling up the installation with the solar agent

7.2 Filling up the installation

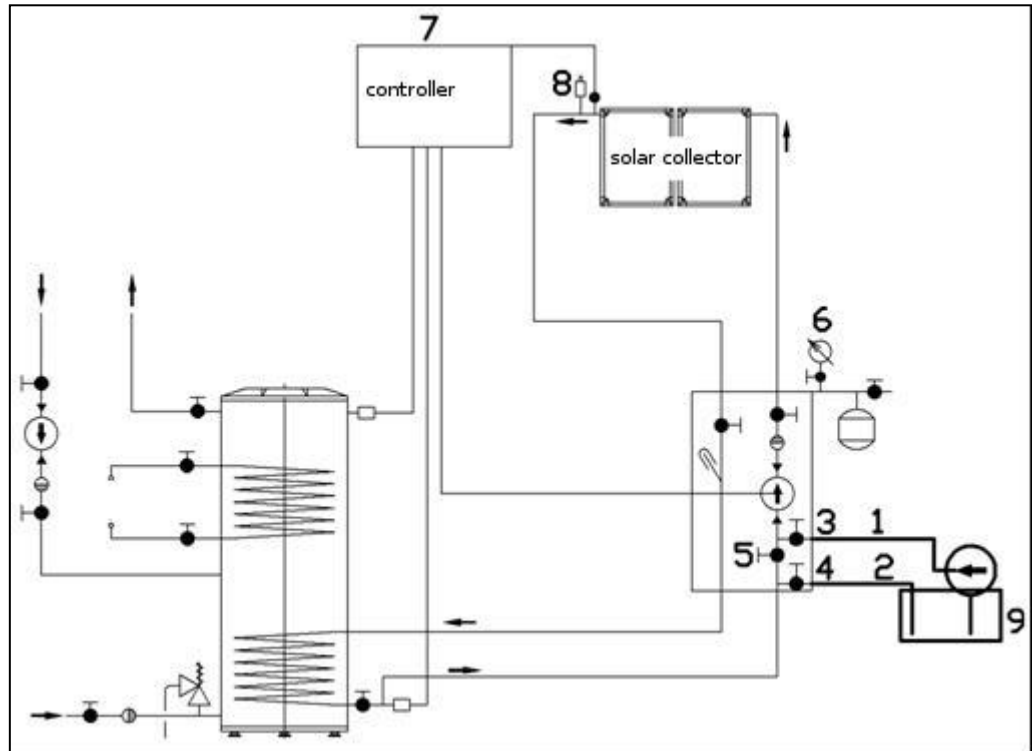

Filling up the installation by using a filling station

1. **Filling station (9):** Connect the hose (1) with the upper valve (3), hose (2) with the bottom valve (4).
2. Fill up the tank of the filling station with the liquid, open the valve (3) and run the pump.
3. Closing the valve (5) will cause the flow through the solar collectors. During filling and venting the system, you should several times open and close the vent (5).
4. Do not turn off the pump until the installation will be *completely* vent -until from the hose stop flowing air bubbles.
5. Open the vent (5) and close the vent (4) and still pump the fluid until the installation will reach the required pressure, $p = 2,5$ bar - Pressure measurement (6).
6. Turn on the controller plug (7) to the network and enable ~ 230V circulation pump in manual mode.
7. Remnants of the air should be removed automatically by unscrewing the valve manually
8. In case of decrease or absence of flow unscrew the central screw in the circulating pump and let the air exhale. Do this exercise until full vent installation.
9. In the case of pressure drop on the Pressure measurement (6) below 1,5 bar complete up to the to the required pressure $p=2,5$
10. bar disconnect the hose from the filling station from the valves (3, 4)

7.3 Venting of the solar installation

After venting the solar installation by means of a filling station and a manual air escape you should close the air escape valve, in case of an automatic air escape it is necessary to close the ball valve.

7.4 Insulation work

Insulation work should be done after performing all inspection operations.

Directions!

–High temperature and weather resistant insulation must be used to insulate the conduits which are outside the building.

If necessary, protect the insulation against damage caused by birds. –High temperature resistant insulation must be used to insulate the conduits inside the building.



8. Maintenance and Service

- During the maintenance and other kind of work a collector must be placed firmly to exclude the danger of tripping over and falling down,
- It is not allowed to perform any repair and maintenance work under a lifted collector which has not been protected against casual falling down,
- Repair and maintenance work should be done by means of suitable tools and the servicing personnel should wear protective gloves and shoes,
- Before the commencement of maintenance work it is necessary to wait till the temperature of a collector lowers to such an extent that a risk of getting scalded by hot elements is excluded,
- Overhaul of the solar system needs to be done in accordance with warranty recommendations for particular elements of the system.

In order to guarantee failure-free operation of the whole system it is recommended to carry out the following maintenance work at least once a year:

Frost protection – check the solar fluid resistance to frost by means of a control device (refractometer). In case of a significant fall in frost resistance of the solar fluid it should be replaced and the system must be deaerated once again.

System pressure – working pressure in the solar system needs to be checked. After the start-up period no drop of pressure is permissible.

Expansion vessel – input pressure of the expansion vessel should be checked. To this end, disconnect the vessel from the system and measure the pressure. The input pressure should be 2,5 bars.

The control and protection system should also be inspected along with the structure for supporting and fixing a collector on the roof.

In order to guarantee the proper operation of the whole system, every time we recommend you to enter into a contract for maintenance work with a specialist installation firm.



Versol Poland | Versol Italy | Versol UK | Versol USA | Versol Middle East | Versol india

